

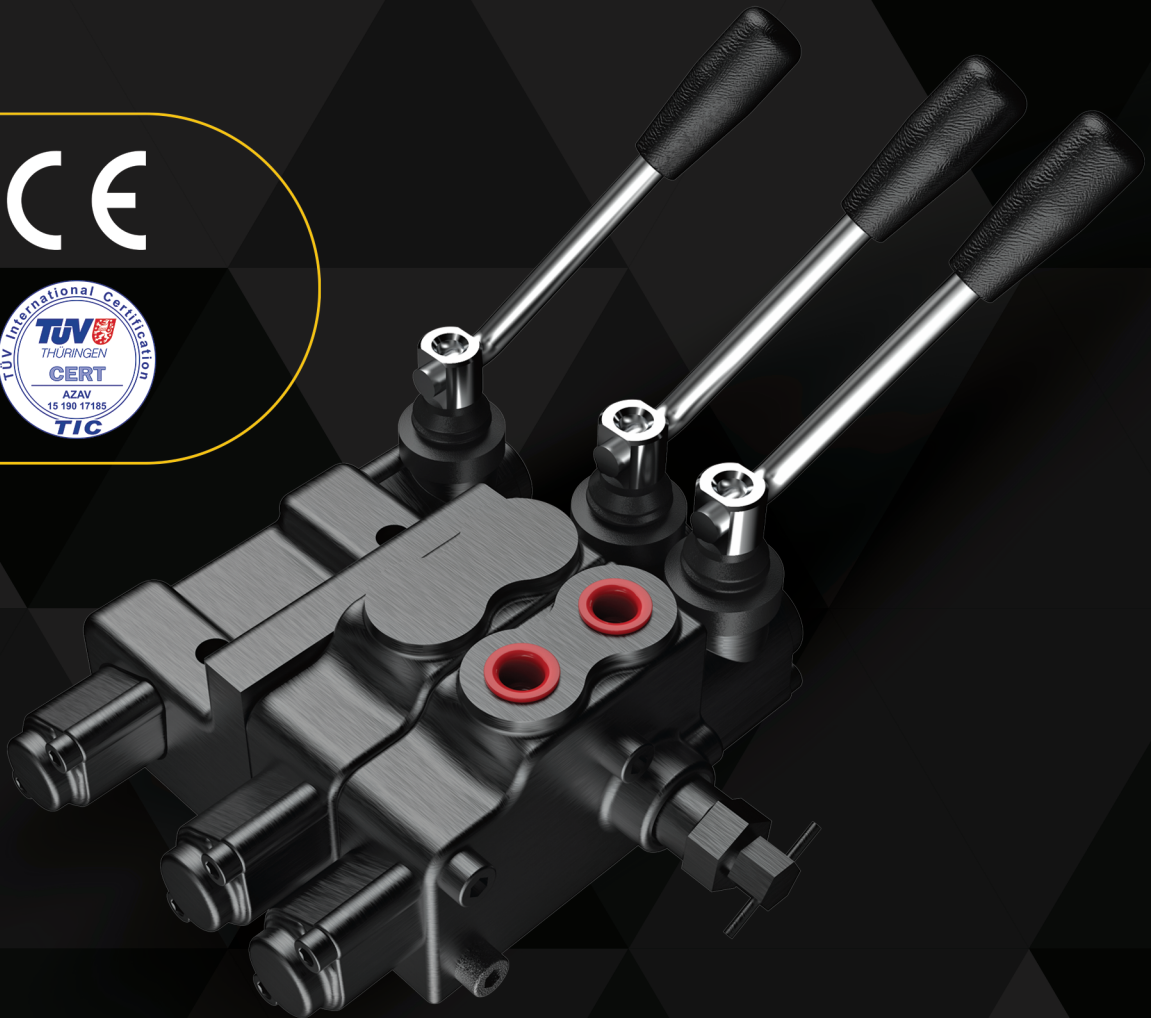

SPECIAL TRACTOR
VALVES

ORV-MF

CE



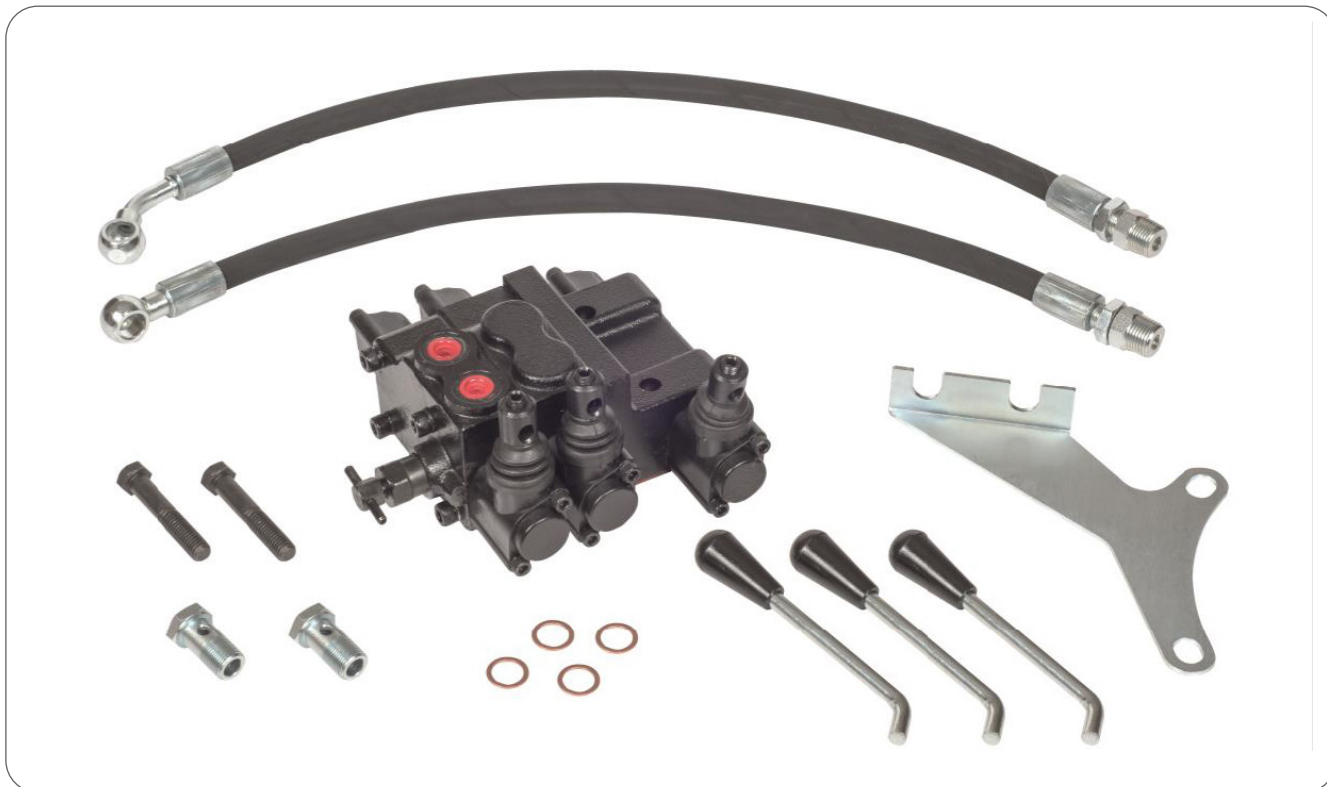

CONTENTS

Working Conditions	401
Dimensional Data	402
Hydraulic Circuit	403
Performance Data And Curve	404
Ports And Mounting Face	405
Ordering Codes And Installation	406

Additional Informations

Note: This catalog shows the product in the most standard configurations. For Other Configurations, more detailed information or special request, Please contact Customer Service Dpt.

Warning! :All specifications of this catalog refer to the standard product at this date (10/2019). ORVAL, oriented to a continuous improvement, reserves the right to discontinue, modify or revise the specifications, without notice.

ORVAL IS NOT RESPONSIBLE FOR ANY DAMAGE CAUSED BY AN INCORRECT USE OF THE PRODUCT.

WORKING CONDITIONS

Nominal Flow Rating / Displacement	45 l/min	12 U.S.G.P.M
Maximum Working Pressure	315 Bar	4600 PSI
Max Back Pressure	25 Bar	360 PSI
Oil Temperature with NBR Seals	-20 to 80 C°	-4 to 176 F°
with FPM (Viton) Seals	-20 to 100 C°	-4 to 212 F°
Oil Viscosity – Operating Range	From 10 to 75 mm ² /s	From 10 to 75 cSt
Minimum / Maximum	10 / 400 mm ² /s	10 / 400 cSt
Oil Filtration	≤30 μ	
Ambiant Temperature Range	-35 to 60 C°	-31 to 140 F°
Number Of Spools	1 to 3	
Internal Leakage (at 100 bar (1450 PSI), 40C° (110 F°), 46 cSt – A(B)–T)	3 cm ³ /min	0,18 in ³ /min
Max. Level Of Contamination	19/16 – ISO 4406	

Not: This catalogue shows technical specifications measured with mineral oil of 46 mm²/s-46 cSt viscosity at 40 C° temperature.

Features

- Simple, compact and heavy duty designed sectional truck mounted valves from 1 to 3 sections for open center hydraulic systems.
- Interchangeable spool diameter is 16 mm – 0,63 in.
- It can be work working section and truck lift for some time.
- It has low tank pressure for additional tank line.
- It can be use single and double acting for only last working section.



DIMENSIONAL DATA

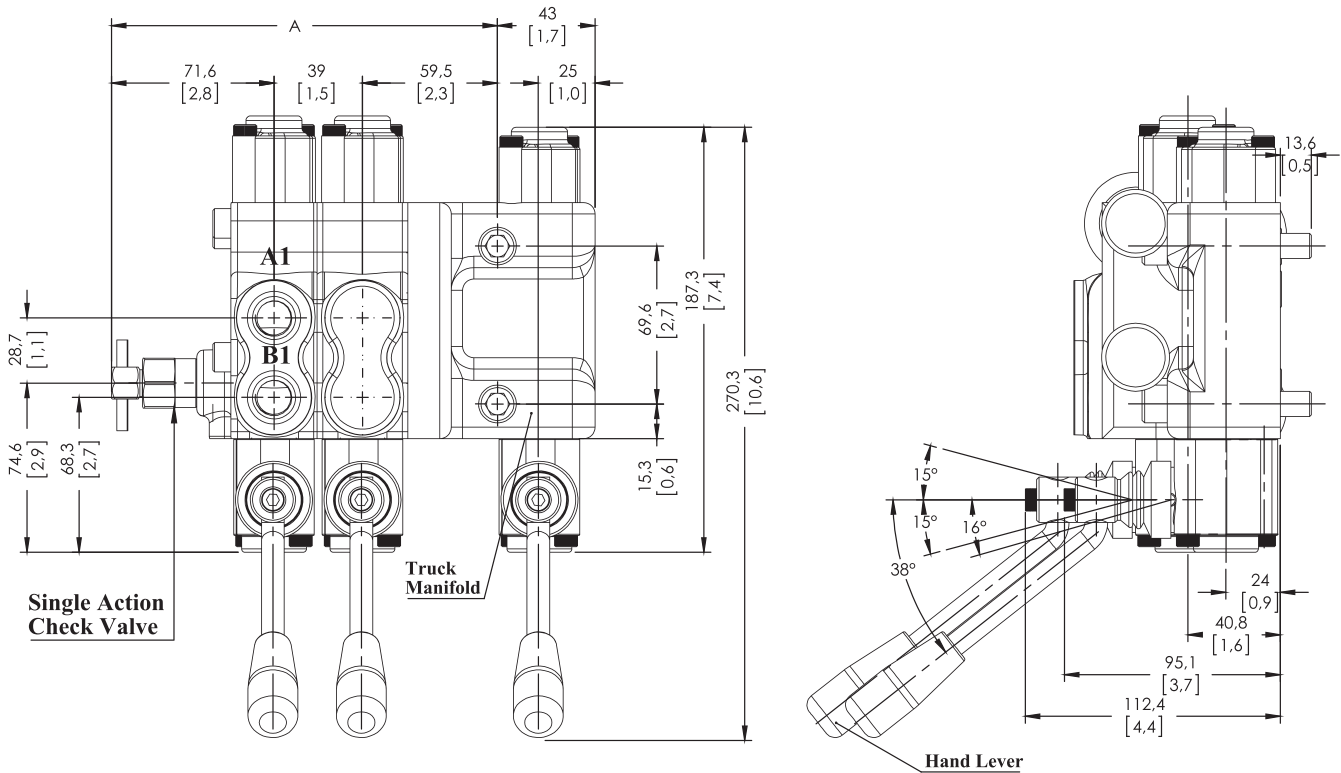

TYPE	A		WEIGHT	
	mm	in	Kg	lb
ORV-MF-2	131	5,16	7,53	16,6
ORV-MF-2+H	170	6,69	9,83	21,67
ORV-MF-4	170	6,69	11,24	24,78
ORV-MF-4+H	209	8,23	13,55	29,87
ORV-MF-6	209	8,23	14,95	32,96

STANDARD THREADS

PORT	BSP (Iso 228)		UN-UNF (Iso 11926-1)	Metric (Iso 262)
	3/8" Series	1/2" Series		
P Inlet			Plate Mounted	
A-B Ports	G 3/8	G 1/2	9/16-18 UNF	M18x1.5
T Outlet			Plate Mounted	

Compatible Models

Massey Ferguson (Old All Models) And
 100 Series – 135, 148, 165, 175, 178, 185, 188
 200 Series – 230, 240, 245, 250, 260, 265, 275, 290, 298
 300 Series – 362, 365, 372, 375, 390, 398, 399
 500 Series – 550, 560, 565, 590, 595

HYDRAULIC CIRCUIT

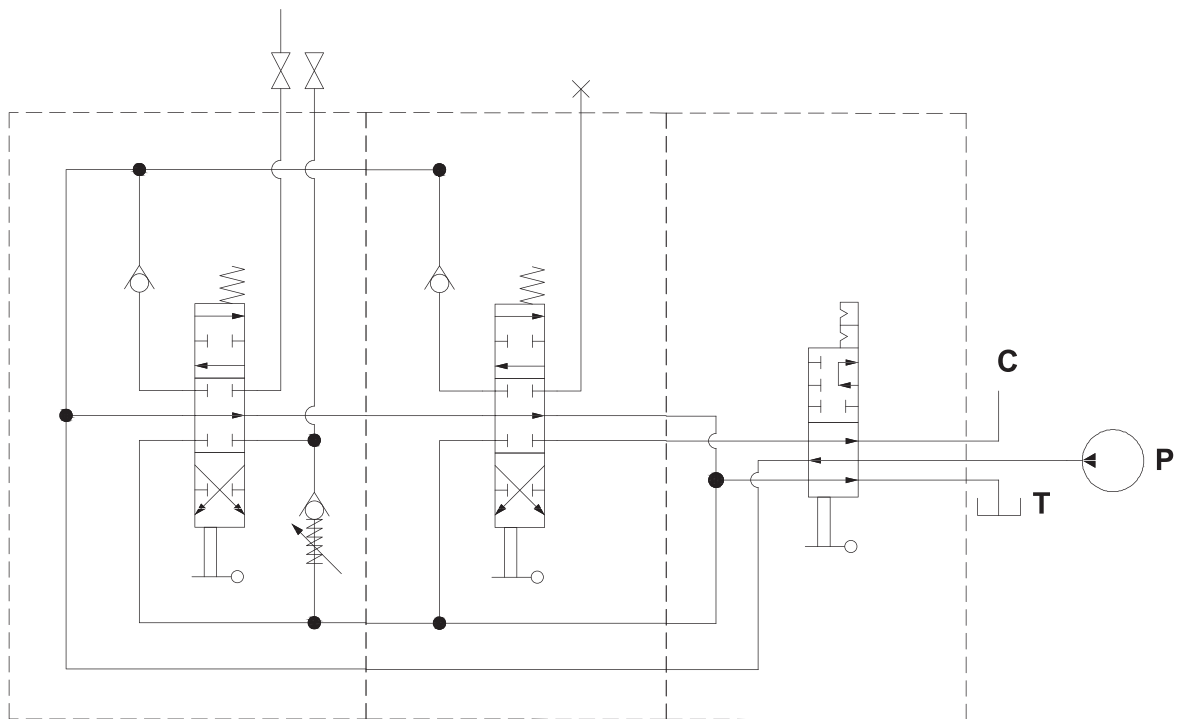
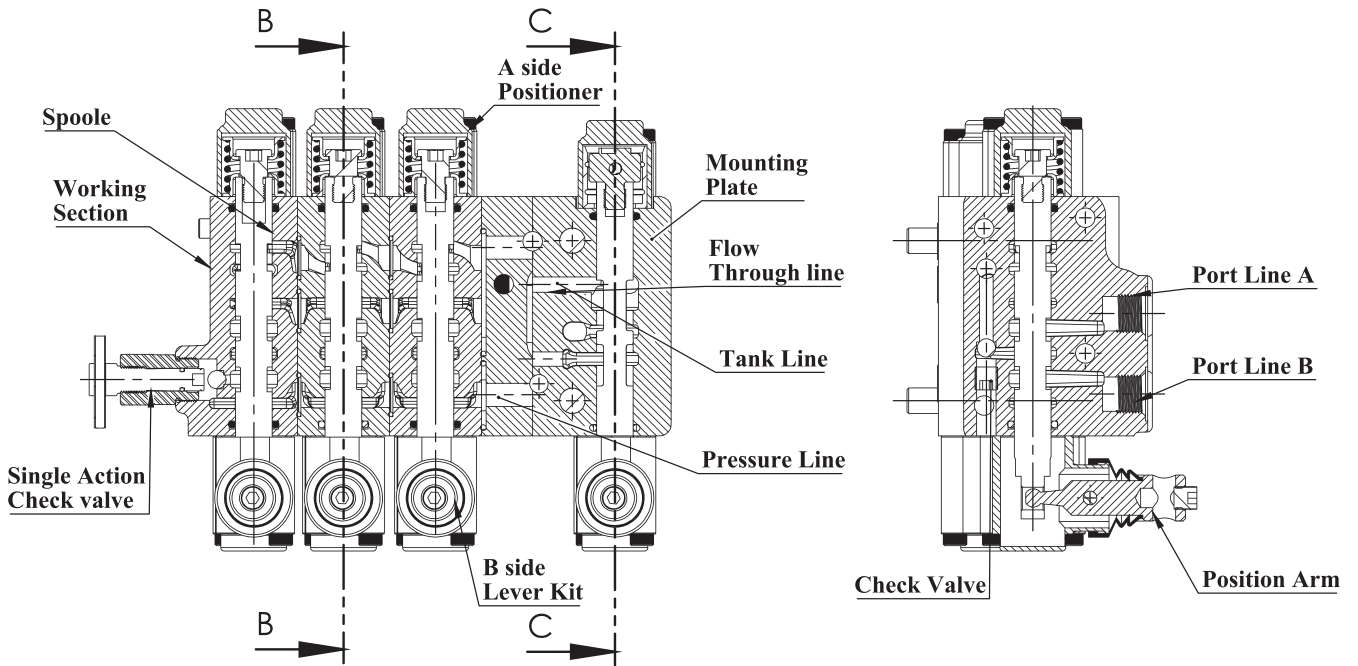

Order Code ORV – MF – 2+H

PERFORMANCE DATA AND CURVE

Open Center - Pressure Drop (P-T)

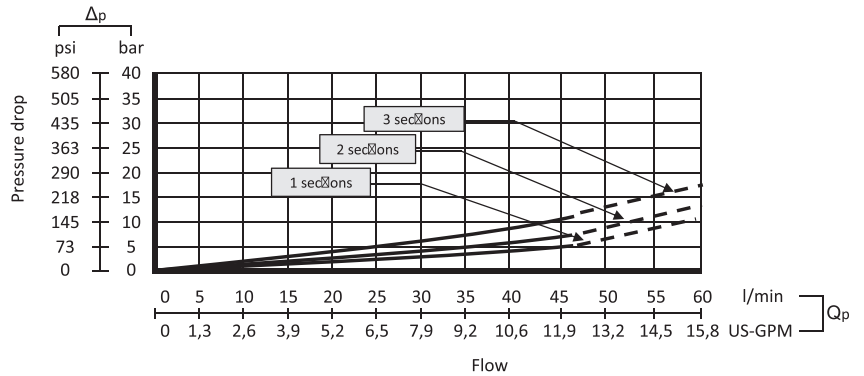
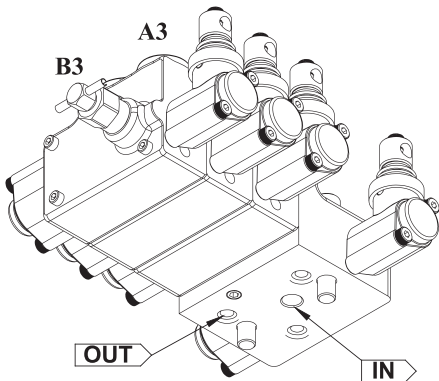

Inlet to Work Port - Pressure Drop (P-A/B)

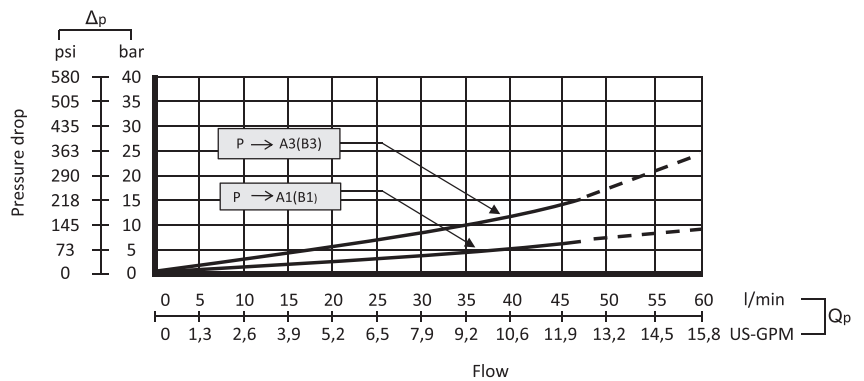
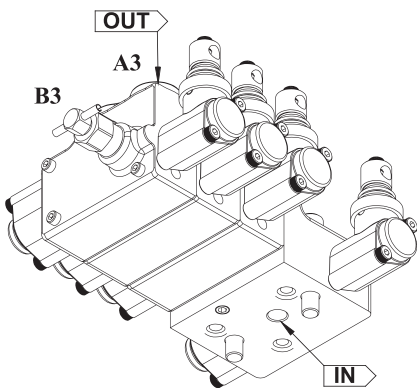

Work Port to Outlet - Pressure Drop (A/B-T)

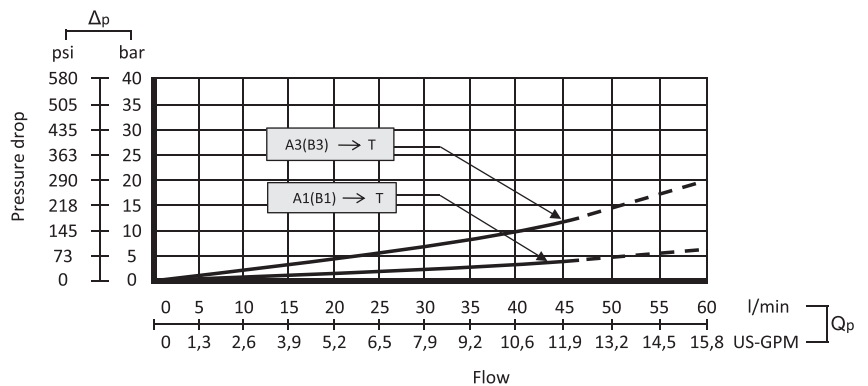
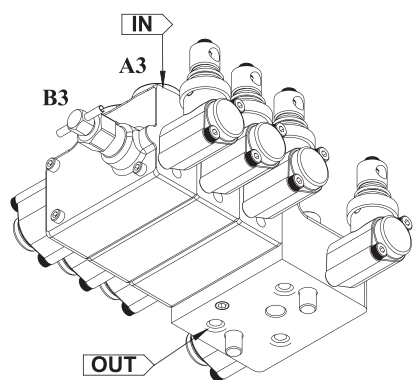

PORTS AND MOUNTING FACE

Port Directional And Type

Port Appearance

Diagram

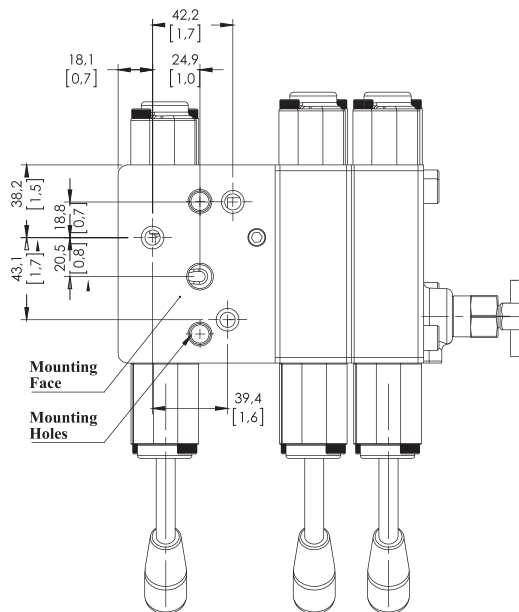
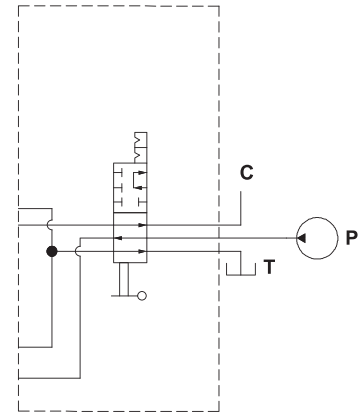
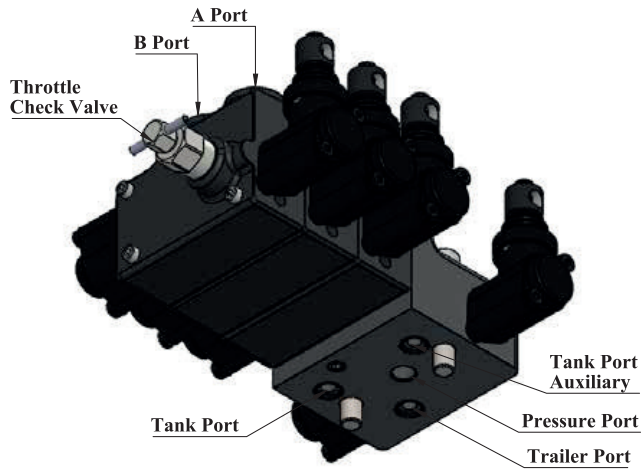

Mounting Face
Technical
Dimension

ORDERING CODES AND INSTALLATION

Order Code

ORV - MF - 2 + H

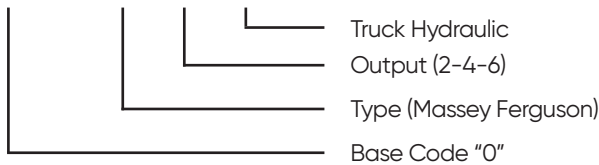

- MF-2 (1 section - 2 Output)
- MF-2 +H (1 section - 2 Output And Truck Hydraulic)
- MF-4 (2 section - 4 Output)
- MF-4 +H (2 section - 4 Output And Truck Hydraulic)
- MF-6 (3 section - 6 Output)
- MF-6 +H (3 section - 6 Output And Truck Hydraulic)

Installation

The ORV MF valve is assembled and tested as per the technical specification of this catalog.

Before the final installation on your equipment, follow the below recommendation:

- The valve can be assembled in any position, in order to prevent body deformation and spool sticking mount the product on a flat surface;
- In order to prevent the possibility of water entering the lever box and spool control kit, do not use high pressure wash down directly on the valve;
- Before painting, ensure plastic port plugs are tightly in place.

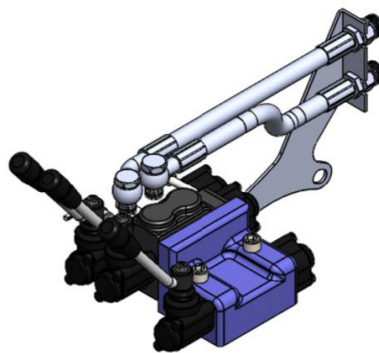



MODEL	HOSE	COUPLING HOLES 3/8"	COPPER WASHER	SHEET CONNECTION	CONNECTION BOLT	LEVER COUNT
ORV - MF-2	56 cm - 1 Pcs / 56 cm - 1 Pcs	2 Pcs	4 Pcs		UNC -7/16-21/2" - 2 Pcs	2 pcs
ORV - MF-2+H	56 cm - 1 Pcs / 56 cm - 1 Pcs	2 Pcs	4 Pcs		UNC -7/16-21/2" - 2 Pcs	3 pcs
ORV - MF-4	62 cm - 2 Pcs / 62 cm - 2 Pcs	4 Pcs	8 Pcs		UNC -7/16-21/2" - 2 Pcs	3 pcs
ORV - MF-4+H	62 cm - 2 Pcs / 62 cm - 2 Pcs	4 Pcs	8 Pcs		UNC -7/16-21/2" - 2 Pcs	4 pcs
ORV - MF-6	62 cm - 3 Pcs / 62 cm - 3 Pcs	6 Pcs	12 Pcs		UNC -7/16-21/2" - 2 Pcs	4 pcs

ORIGINAL VALVE



 BÜsan Org. San. Fevzi Çakmak Mah. Kosgeb Cad.
10641. Sk. No: 37 Karatay/KONYA/TÜRKİYE

 +90 332 345 29 29  +90 332 345 29 23

 satis@orval.com.tr  bilgi@orval.com.tr

